

# Oscillating Edge Sander

(Model 31-396)

INSTRUCTION MANUAL



PART NO. 909448 - 03-18-03  
Copyright © 2003 Delta Machinery

 **DELTA<sup>®</sup> INDUSTRIAL**

To learn more about DELTA MACHINERY  
visit our website at: [www.deltamachinery.com](http://www.deltamachinery.com).

For Parts, Service, Warranty or other Assistance,

please call **1-800-223-7278** (In Canada call **1-800-463-3582**).

# SAFETY GUIDELINES - DEFINITIONS

This manual contains information that is important for you to know and understand. This information relates to protecting YOUR SAFETY and PREVENTING EQUIPMENT PROBLEMS. To help you recognize this information, we use the symbols to the right. Please read the manual and pay attention to these sections.

**▲ DANGER** Indicates an imminently hazardous situation which, if not avoided, will result in death or serious injury.

**▲ WARNING** Indicates a potentially hazardous situation which, if not avoided, could result in death or serious injury.

**▲ CAUTION** Indicates a potentially hazardous situation which, if not avoided, may result in minor or moderate injury.

**CAUTION** Used without the safety alert symbol indicates potentially hazardous situation which, if not avoided, may result in property damage.

**▲ WARNING** **SOME DUST CREATED BY POWER SANDING, SAWING, GRINDING, DRILLING, AND OTHER CONSTRUCTION ACTIVITIES** contains chemicals known to cause cancer, birth defects or other reproductive harm. Some examples of these chemicals are:

- lead from lead-based paints,
- crystalline silica from bricks and cement and other masonry products, and
- arsenic and chromium from chemically-treated lumber.

Your risk from these exposures varies, depending on how often you do this type of work. To reduce your exposure to these chemicals: work in a well ventilated area, and work with approved safety equipment, always wear **MSHA/NIOSH** approved, properly fitting face mask or respirator when using such tools.

## GENERAL SAFETY RULES



**▲ WARNING** **READ AND UNDERSTAND ALL WARNINGS AND OPERATING INSTRUCTIONS BEFORE USING THIS EQUIPMENT.** Failure to follow all instructions listed below, may result in electric shock, fire, and/or serious personal injury or property damage.

**SAVE! IMPORTANT SAFETY INSTRUCTIONS SAVE!**

Woodworking can be dangerous if safe and proper operating procedures are not followed. As with all machinery, there are certain hazards involved with the operation of the product. Using the machine with respect and caution will considerably lessen the possibility of personal injury. However, if normal safety precautions are overlooked or ignored, personal injury to the operator may result. Safety equipment such as guards, push sticks, hold-downs, featherboards, goggles, dust masks and hearing protection can reduce your potential for injury. But even the best guard won't make up for poor judgment, carelessness or inattention. Always use common sense and exercise caution in the workshop. If a procedure feels dangerous, don't try it. Figure out an alternative procedure that feels safer. **REMEMBER:** Your personal safety is your responsibility.

This machine was designed for certain applications only. Delta Machinery strongly recommends that this machine not be modified and/or used for any application other than that for which it was designed. If you have any questions relative to a particular application, **DO NOT** use the machine until you have first contacted Delta to determine if it can or should be performed on the product.

### Technical Service Manager

Delta Machinery

4825 Highway 45 North

Jackson, TN 38305

(IN CANADA: 505 SOUTHGATE DRIVE, GUELPH, ONTARIO N1H 6M7)

1. **FOR YOUR OWN SAFETY, READ THE INSTRUCTION MANUAL BEFORE OPERATING THE MACHINE.** Learning the machine's application, limitations, and specific hazards will greatly minimize the possibility of accidents and injury.

2. **USE CERTIFIED SAFETY EQUIPMENT.** Eye protection equipment should comply with ANSI Z87.1 standards, hearing equipment should comply with ANSI S3.19 standards, and dust mask protection should comply with MSHA/NIOSH certified respirator standards. Splinters, air-borne debris, and dust can cause irritation, injury, and/or illness.

3. **DRESS PROPERLY.** Do not wear tie, gloves, or loose clothing. Remove watch, rings, and other jewelry. Roll up your sleeves. Clothing or jewelry caught in moving parts can cause injury.

4. **DO NOT USE THE MACHINE IN A DANGEROUS ENVIRONMENT.** The use of power tools in damp or wet locations or in rain can cause shock or electrocution. Keep your work area well-lit to prevent tripping or placing arms, hands, and fingers in danger.

5. **MAINTAIN ALL TOOLS AND MACHINES IN PEAK CONDITION.** Keep tools sharp and clean for best and safest performance. Follow instructions for lubricating and changing accessories. Poorly maintained tools and machines can further damage the tool or machine and/or cause injury.

6. **CHECK FOR DAMAGED PARTS.** Before using the machine, check for any damaged parts. Check for alignment of moving parts, binding of moving parts, breakage of parts, and any other conditions that may affect its operation. A guard or any other part that is damaged **should be properly repaired or replaced.** Damaged parts can cause further damage to the machine and/or injury.

7. **KEEP THE WORK AREA CLEAN.** Cluttered areas and benches invite accidents.

8. **KEEP CHILDREN AND VISITORS AWAY.** Your shop is a potentially dangerous environment. Children and visitors can be injured.

9. **REDUCE THE RISK OF UNINTENTIONAL STARTING.** Make sure that the switch is in the "OFF" position before plugging in the power cord. In the event of a power failure, move the switch to the "OFF" position. An accidental start-up can cause injury.

10. **USE THE GUARDS.** Check to see that all guards are in place, secured, and working correctly to prevent injury.

11. **REMOVE ADJUSTING KEYS AND WRENCHES BEFORE STARTING THE MACHINE.** Tools, scrap pieces, and other debris can be thrown at high speed, causing injury.

12. **USE THE RIGHT MACHINE.** Don't force a machine or an attachment to do a job for which it was not designed. Damage to the machine and/or injury may result.

13. **USE RECOMMENDED ACCESSORIES.** The use of accessories and attachments not recommended by Delta may cause damage to the machine or injury to the user.

14. **USE THE PROPER EXTENSION CORD.** Make sure your extension cord is in good condition. When using an extension cord, be sure to use one heavy enough to carry the current your product will draw. An undersized cord will cause a drop in line voltage, resulting in loss of power and overheating. See the Extension Cord Chart for the correct size depending on the cord length and nameplate ampere rating. If in doubt, use the next heavier gauge. The smaller the gauge number, the heavier the cord.

15. **SECURE THE WORKPIECE.** Use clamps or a vise to hold the workpiece when practical. Loss of control of a workpiece can cause injury.

16. **FEED THE WORKPIECE AGAINST THE DIRECTION OF THE ROTATION OF THE BLADE, CUTTER, OR ABRASIVE SURFACE.** Feeding it from the other direction will cause the workpiece to be thrown out a high speed.

17. **DON'T FORCE THE WORKPIECE ON THE MACHINE.** Damage to the machine and/or injury may result.

18. **DON'T OVERREACH.** Loss of balance can make you fall into a working machine, causing injury.

19. **NEVER STAND ON THE MACHINE.** Injury could occur if the tool tips, or if you accidentally contact the cutting tool.

20. **NEVER LEAVE THE MACHINE RUNNING UNATTENDED. TURN THE POWER OFF.** Don't leave the machine until it comes to a complete stop. A child or visitor could be injured.

21. **TURN THE MACHINE "OFF", AND DISCONNECT THE MACHINE FROM THE POWER SOURCE** before installing or removing accessories, before adjusting or changing set-ups, or when making repairs. An accidental start-up can cause injury.

22. **MAKE YOUR WORKSHOP CHILDPROOF WITH PADLOCKS, MASTER SWITCHES, OR BY REMOVING STARTER KEYS.** The accidental start-up of a machine by a child or visitor could cause injury.

23. **STAY ALERT, WATCH WHAT YOU ARE DOING, AND USE COMMON SENSE. DO NOT USE THE MACHINE WHEN YOU ARE TIRED OR UNDER THE INFLUENCE OF DRUGS, ALCOHOL, OR MEDICATION.** A moment of inattention while operating power tools may result in injury.

24. **THE DUST GENERATED** by certain woods and wood products can be injurious to your health. Always operate machinery in well-ventilated areas, and provide for proper dust removal. Use wood dust collection systems whenever possible.

## ADDITIONAL SAFETY RULES FOR ABRASIVE FINISHING MACHINES

**▲WARNING FAILURE TO FOLLOW THESE RULES MAY RESULT IN SERIOUS PERSONAL INJURY.**

1. **DO NOT OPERATE THIS MACHINE UNTIL** it is assembled and installed according to the instructions.
2. **OBTAIN ADVICE** from your supervisor, instructor, or another qualified person if you are not familiar with the operation of this machine.
3. **FOLLOW ALL WIRING CODES** and recommended electrical connections.
4. **USE THE GUARDS WHENEVER POSSIBLE.** Check to see that they are in place, secured, and working correctly.
5. **CHECK BELTS** for wear and tension. If the belt is damaged or can't be tensioned properly, replace it.
6. **CHECK FOR CORRECT BELT INSTALLATION,** and insure that the belt is tracking properly.
7. **KEEP ARMS, HANDS, AND FINGERS** away from abrasive surfaces.
8. **AVOID AWKWARD OPERATIONS AND HAND POSITIONS** where a sudden slip could cause a hand to contact the sanding surface.
9. **NEVER WEAR GLOVES** or hold the workpiece with a rag when sanding.
10. **NEVER START THE MACHINE** with the workpiece against the sanding surface.
11. **NEVER START THE MACHINE** before clearing the table of all objects (tools, scrap pieces, etc.).
12. **MAINTAIN MINIMUM CLEARANCE** between the table and the sanding surface.
13. **USE A BACKSTOP** when using the belt finishing machine in a horizontal position.
14. **FEED THE WORKPIECE AGAINST THE ROTATION OF THE SANDING SURFACE.** Hold the workpiece securely on the table.
15. **USE A DUST COLLECTION SYSTEM.**
16. **CLEAN THE MACHINE AND DUST COLLECTION SYSTEM THOROUGHLY BEFORE AND AFTER SANDING METAL.** Combining wood dust and metal filings (or aluminum filings and metal filings) can create a fire hazard. DO NOT sand magnesium. It is highly flammable.
17. **FOR DRUM SANDERS, DO NOT SAND WORKPIECES SHORTER THAN 7" or thinner than 1/32".**
18. **PROPERLY SUPPORT LONG OR WIDE** workpieces.
19. **DISCONNECT THE MACHINE** from the power source before installing or removing accessories, before adjusting or changing set-ups, or when making repairs.
20. **DISCONNECT THE MACHINE** from the power source, and clean the table/work area before leaving the machine. **LOCK THE SWITCH IN THE "OFF" POSITION** to prevent unauthorized use.
21. **ADDITIONAL INFORMATION** regarding the safe and proper operation of this machine is available from the Power Tool Institute, 1300 Summer Avenue, Cleveland, OH 44115-2851. Information is also available from the National Safety Council, 1121 Spring Lake Drive, Itasca, IL 60143-3201. Please refer to the American National Standards Institute ANSI 01.1 Safety Requirements for Woodworking Machines and the U.S. Department of Labor OSHA 1910.213 Regulations.

**SAVE THESE INSTRUCTIONS.  
Refer to them often and use them to instruct others.**

## POWER CONNECTIONS

A separate electrical circuit should be used for your machines. This circuit should not be less than #12 wire and should be protected with a 20 Amp time lag fuse. If an extension cord is used, use only 3-wire extension cords which have 3-prong grounding type plugs and matching receptacle which will accept the machine's plug. Before connecting the machine to the power line, make sure the switch is "OFF" and be sure that the electric current is of the same characteristics as indicated on the machine. All line connections should make good contact. Running on low voltage will damage the machine.

**⚠ DANGER DO NOT EXPOSE THE MACHINE TO RAIN OR OPERATE THE MACHINE IN DAMP LOCATIONS.**

## MOTOR SPECIFICATIONS

Your machine is wired for 220 volt, 60 HZ alternating current. Before connecting the machine to the power source, make sure the switch is in the "OFF" position.

## GROUNDING INSTRUCTIONS

**⚠ DANGER THIS MACHINE MUST BE GROUNDED WHILE IN USE TO PROTECT THE OPERATOR FROM ELECTRIC SHOCK.**

### 1. All grounded, cord-connected machines:

In the event of a malfunction or breakdown, grounding provides a path of least resistance for electric current to reduce the risk of electric shock. This machine is equipped with an electric cord having an equipment-grounding conductor and a grounding plug. The plug must be plugged into a matching outlet that is properly installed and grounded in accordance with all local codes and ordinances.

Do not modify the plug provided - if it will not fit the outlet, have the proper outlet installed by a qualified electrician.

Improper connection of the equipment-grounding conductor can result in risk of electric shock. The conductor with insulation having an outer surface that is green with or without yellow stripes is the equipment-grounding conductor. If repair or replacement of the electric cord or plug is necessary, do not connect the equipment-grounding conductor to a live terminal.

Check with a qualified electrician or service personnel if the grounding instructions are not completely understood, or if in doubt as to whether the machine is properly grounded.

Use only 3-wire extension cords that have 3-prong grounding type plugs and matching 3-conductor receptacles that accept the machine's plug, as shown in Fig. C.

Repair or replace damaged or worn cord immediately.

### 2. Grounded, cord-connected machines intended for use on a supply circuit having a nominal rating between 150 - 250 volts, inclusive:

If the machine is intended for use on a circuit that has an outlet that looks like the one illustrated in Fig. C, the machine will have a grounding plug that looks like the plug illustrated in Fig. C. Make sure the machine is connected to an outlet having the same configuration as the plug. No adapter is available or should be used with this machine. If the machine must be re-connected for use on a different type of electric circuit, the re-connection should be made by qualified service personnel; and after re-connection, the machine should comply with all local codes and ordinances.

**⚠ DANGER IN ALL CASES, MAKE CERTAIN THE RECEPTACLE IN QUESTION IS PROPERLY GROUNDED. IF YOU ARE NOT SURE HAVE A QUALIFIED ELECTRICIAN CHECK THE RECEPTACLE.**

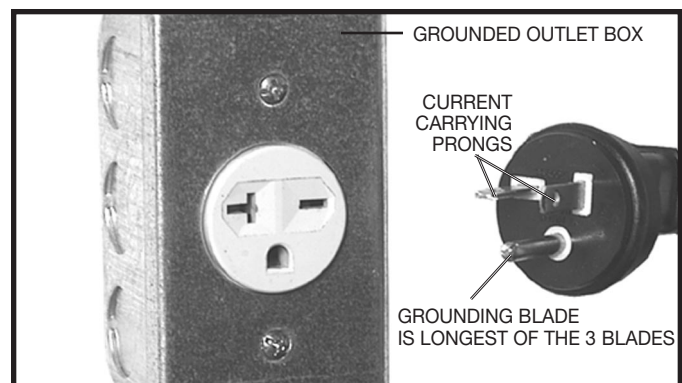

Fig. C

# EXTENSION CORDS

**CAUTION** Use proper extension cords. Make sure your extension cord is in good condition and is a 3-wire extension cord which has a 3-prong grounding type plug and matching receptacle which will accept the machine's plug. When using an extension cord, be sure to use one heavy enough to carry the current of the machine. An undersized cord will cause a drop in line voltage, resulting in loss of power and overheating. Fig. D, shows the correct gauge to use depending on the cord length. If in doubt, use the next heavier gauge. The smaller the gauge number, the heavier the cord.

<b>MINIMUM GAUGE EXTENSION CORD</b>			
RECOMMENDED SIZES FOR USE WITH STATIONARY ELECTRIC MACHINES			
Ampere Rating	Volts	Total Length of Cord in Feet	Gauge of Extension Cord
0-6	240	up to 50	18 AWG
0-6	240	50-100	16 AWG
0-6	240	100-200	16 AWG
0-6	240	200-300	14 AWG
6-10	240	up to 50	18 AWG
6-10	240	50-100	16 AWG
6-10	240	100-200	14 AWG
6-10	240	200-300	12 AWG
10-12	240	up to 50	16 AWG
10-12	240	50-100	16 AWG
10-12	240	100-200	14 AWG
10-12	240	200-300	12 AWG
12-16	240	up to 50	14 AWG
12-16	240	50-100	12 AWG
12-16	240	GREATER THAN 100 FEET NOT RECOMMENDED	

Fig. D

# FUNCTIONAL DESCRIPTION

## FOREWORD

Delta Model 31-396 is an Oscillating Edge Sander. The model 31-396 is powered by a 3 H.P., 220 volt single phase motor. The oscillating edge belt can be positioned anywhere from 0 degrees to the table to 90 degrees to the table. The model 31-396 also comes with a spindle sander attachment kit that is used for sanding curved surfaces.

# UNPACKING AND CLEANING

Carefully unpack the machine and all loose items from the shipping container(s). Remove the protective coating from all unpainted surfaces. This coating may be removed with a soft cloth moistened with kerosene (do not use acetone, gasoline or lacquer thinner for this purpose). After cleaning, cover the unpainted surfaces with a good quality household floor paste wax.

**NOTICE: THE MANUAL COVER PHOTO ILLUSTRATES THE CURRENT PRODUCTION MODEL. ALL OTHER ILLUSTRATIONS ARE REPRESENTATIVE ONLY AND MAY NOT DEPICT THE ACTUAL COLOR, LABELING OR ACCESSORIES AND MAY BE INTENDED TO ILLUSTRATE TECHNIQUE ONLY.**

1. Open door (A) Fig. 1, on front of machine, by sliding latch lock (B) back, and pulling out on door.

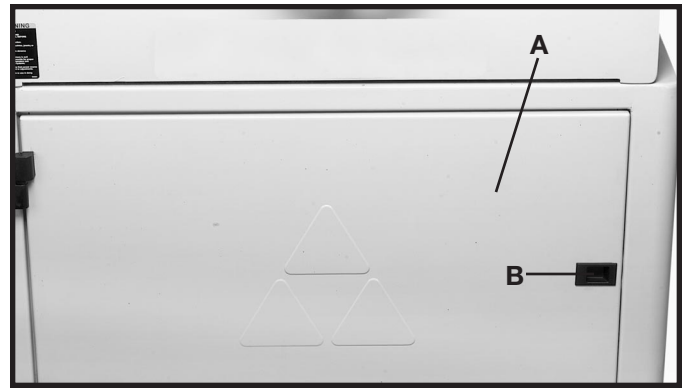

Fig. 1

2. Remove the two screws (C) Fig. 2, and remove the sanding fence (D).

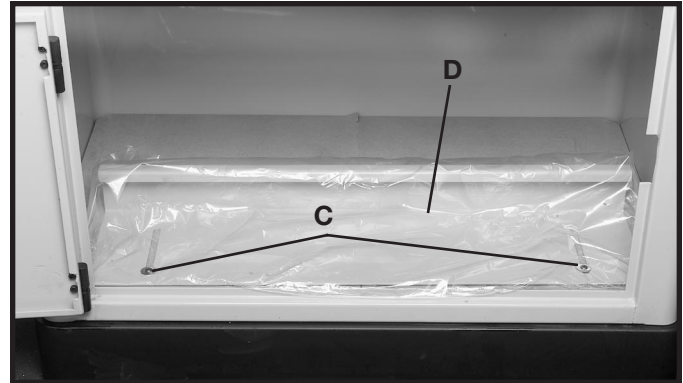

Fig. 2

3. Lift up on hook (H) Fig. 3, and remove the shelves (J) and (K).

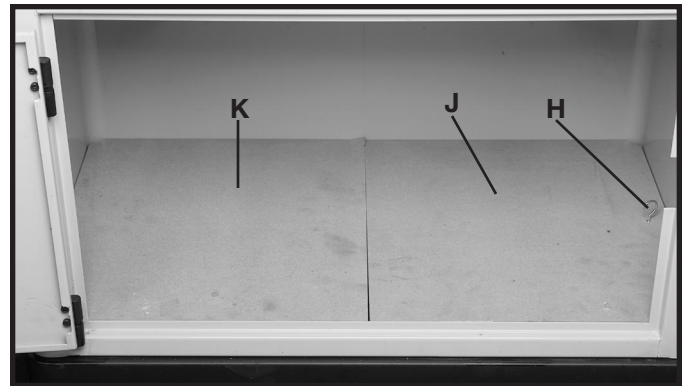

Fig. 3

4. Remove the four screws that attach the sander base to the shipping skid. Note: Two of the screws are shown at (L) Fig. 4.

5. **⚠ CAUTION THE MACHINE IS EXTREMELY HEAVY. HAVE FOUR OR MORE PEOPLE LIFT THE MACHINE OFF THE SHIPPING SKID.**

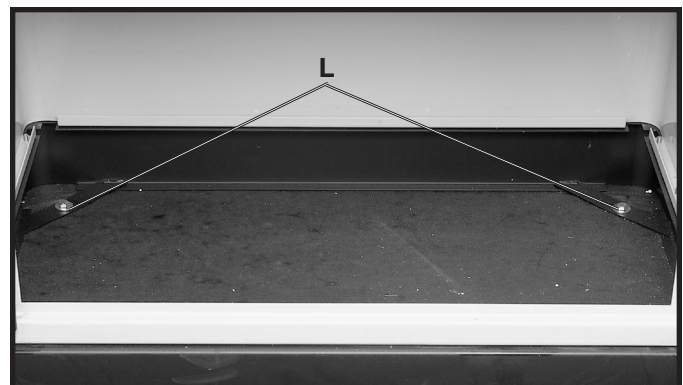

Fig. 4

# OSCILLATING EDGE SANDER PARTS

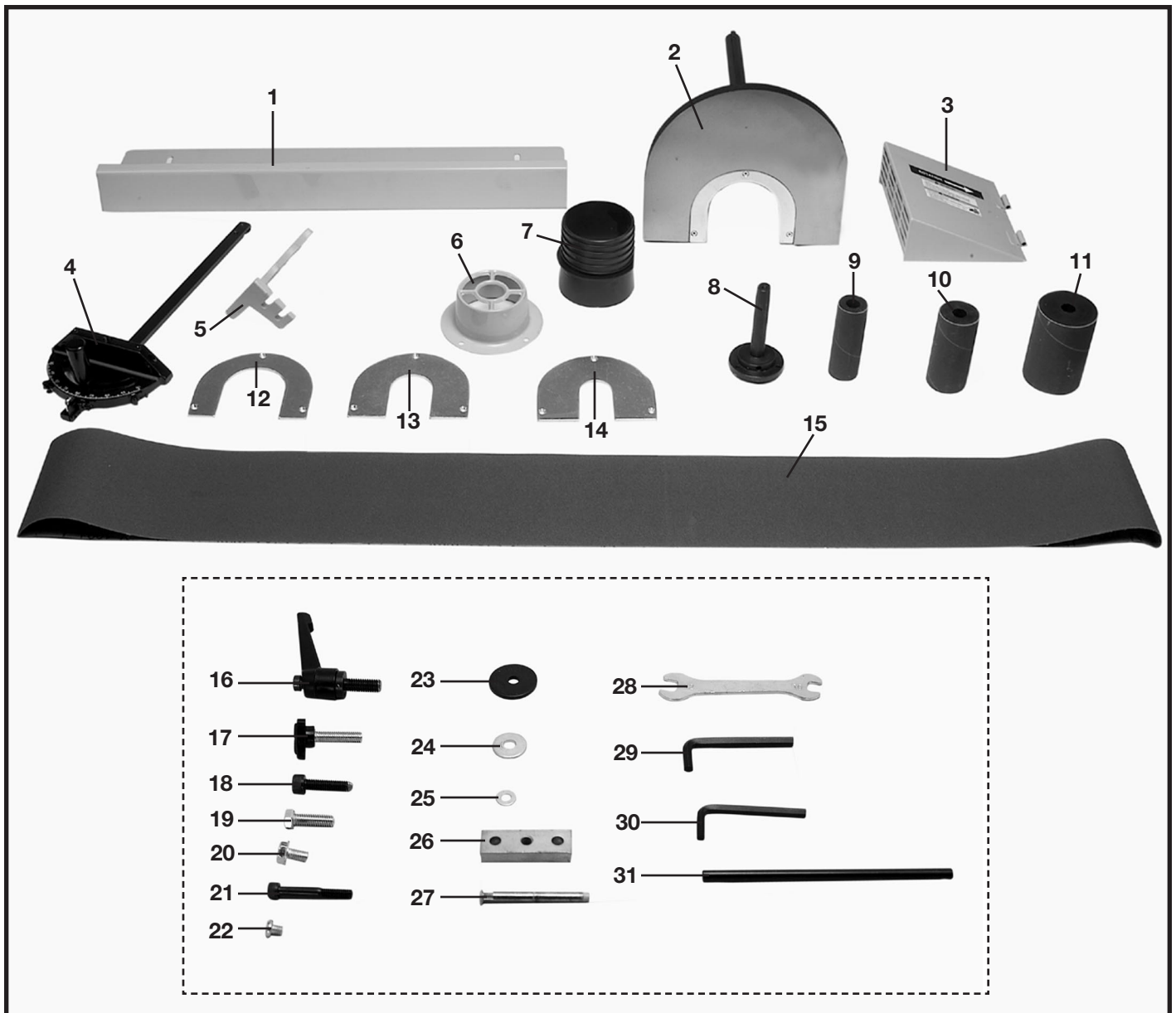

Fig. 5

- |                         |  |
|-------------------------|--|
| 1. Fence                | 17. Fence Knob (2)                                       |
| 2. Table Assembly       | 18. 5/16-18 x 1-1/4" Socket Head Screw (1) (maintenance) |
| 3. Cover                | 19. 5/16-18 x 1" Hex Head Screw (2)                      |
| 4. Miter Gage           | 20. 5/16-18 x 1/2" Hex Head Screw (1)                    |
| 5. Back Stop            | 21. 1/4-20 x 1-3/4" Socket Head Screw (2) (maintenance)  |
| 6. Dust Port            | 22. 1/4-20 x 3/8" Round Head Screw (4)                   |
| 7. 4" Hose Connector    | 23. 5/16" Spindle Washer (1)                             |
| 8. Spindle              | 24. 5/16" Flat Washer (4)                                |
| 9. 1 1/2" Dia. Drum     | 25. 17/64" Flat Washer (4)                               |
| 10. 2" Dia. Drum        | 26. Plate (maintenance)                                  |
| 11. 3" Dia. Drum        | 27. Hinge Pin (2)  |
| 12. 3" Table Insert     | 28. 10mm x 12mm Open End Wrench                          |
| 13. 2" Table Insert     | 29. M6 Hex Wrench  |
| 14. 1 1/2" Table Insert | 30. M5 Hex Wrench  |
| 15. Sanding Belt        | 31. Rod  |
| 16. Ratchet Handle      |  |

# ASSEMBLY

**⚠ WARNING** FOR YOUR OWN SAFETY, DO NOT CONNECT THE MACHINE TO THE POWER SOURCE UNTIL THE MACHINE IS COMPLETELY ASSEMBLED AND YOU READ AND UNDERSTAND THE ENTIRE INSTRUCTION MANUAL.

## BELT

1. Remove knobs (C) and (D) Fig. 6.
2. Open latch (B) Fig. 6, and carefully lower cover (F).
3. Open latch (A) Fig. 6, and carefully lower cover (E).

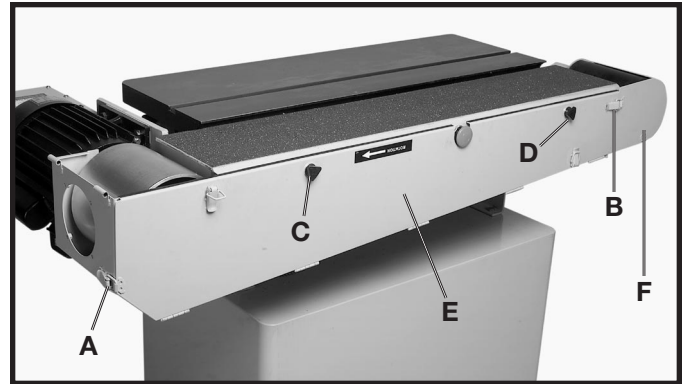

Fig. 6

4. Pull out belt tension lever (G) Fig. 8.



Fig. 8

5. **NOTE: MAKE SURE THE ROTATION ARROW ON THE INSIDE OF THE BELT IS POINTING IN THE SAME DIRECTION AS THE ROTATION ARROW ON THE MACHINE.** Place belt (K) over the two belt drums (H) and (J) Fig. 9. Make sure the belt is centered on the drums.

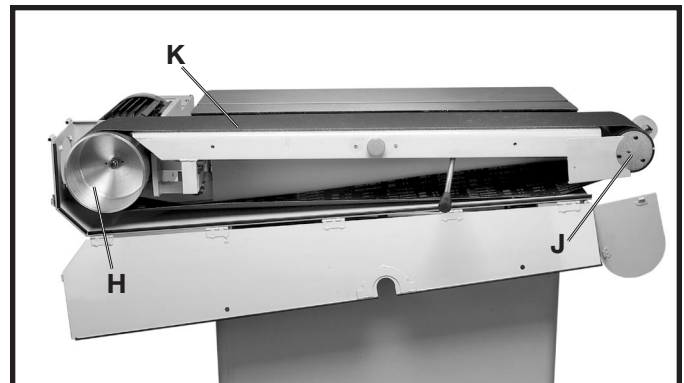

Fig. 9



6. Slowly release the belt tension lever handle (G) Fig. 10, by grasping the lever handle (G) and pushing it in until it stops.

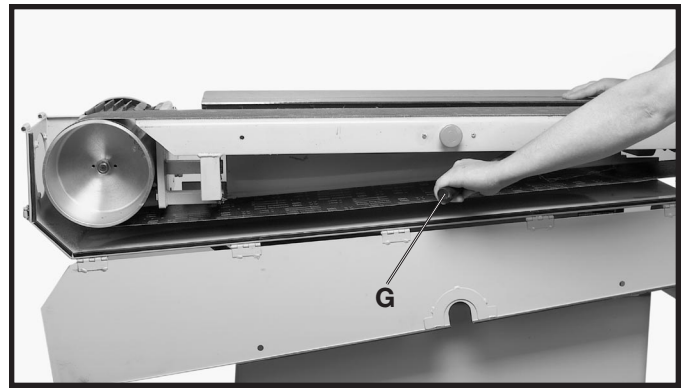

Fig. 10

7. Raise the belt guards (E) and (F) Fig. 11.

8. Latch levers (A) and (B) Fig. 11 to belt guards (E) and (F).

9. Replace knobs (C) and (D) Fig. 11, that were removed in **STEP 1**.

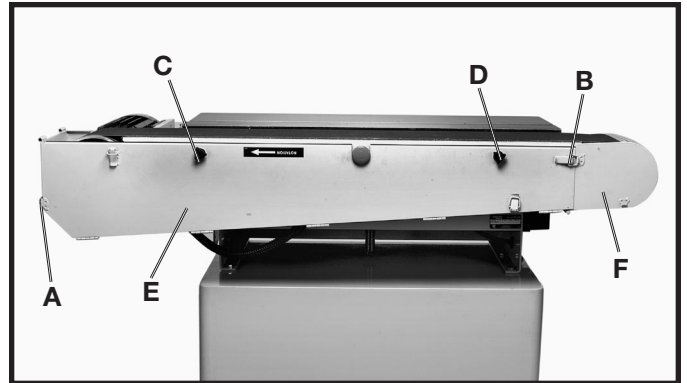

Fig. 11

## BACK STOP

**NOTE: THE BOTTOM OF THE BACK STOP (C) FIG. 13 SHOULD BE SET SLIGHTLY ABOVE THE BELT SANDER TABLE.**

1. Place a 5/16" flat washer on each 5/16-18 x 1" hex head screw. Thread screws into table two complete turns.

2. Place back stop (A) Fig. 12, on screws (B) between table and washers and tighten securely.

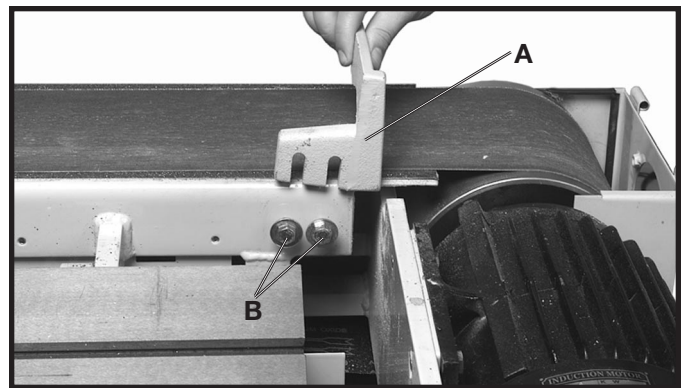

Fig. 12

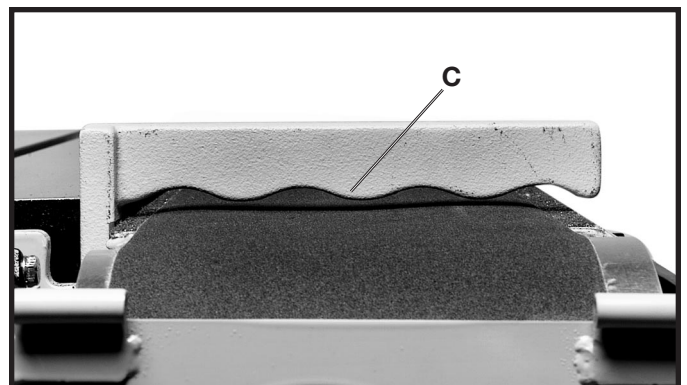

Fig. 13

# COVER

1. Align the hinges (A) Fig. 14, on the cover, with the hinges (B) on the belt guard.

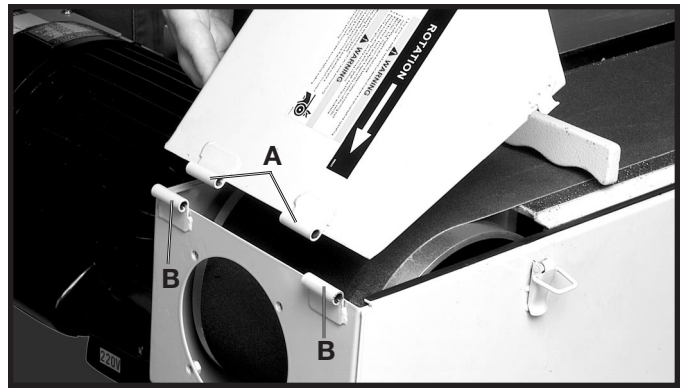

Fig. 14

2. Insert hinge pins (C) and (D) Fig. 15, through the hinges on the cover and belt guard.

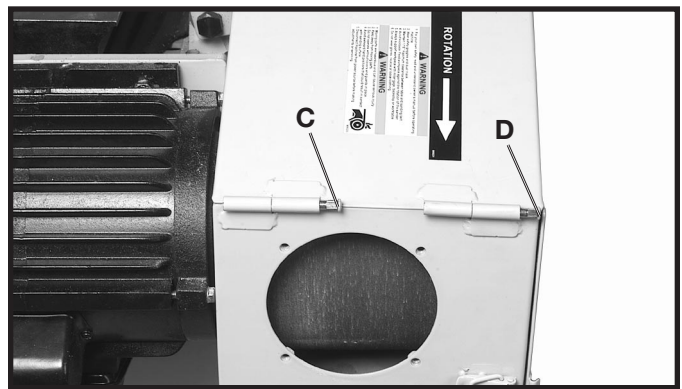

Fig. 15

3. Tap the hinge pins in with hammer and rod (supplied).

4. Latch lever (E) Fig. 16 to the cover.



Fig. 16

## DUST PORT

1. Align the four holes on the dust port (A) Fig. 17, with the four tapped holes (B) on the side of the belt sander.
2. Place a  $17/64$ " flat washer on a  $1/4$ -20x $3/8$ " round head screw, insert the screw through the hole in the dust port, and thread the screw into the tapped hole on the side of the belt sander. Repeat this process for the three remaining holes in the dust port and belt sander. Tighten all four screws securely.

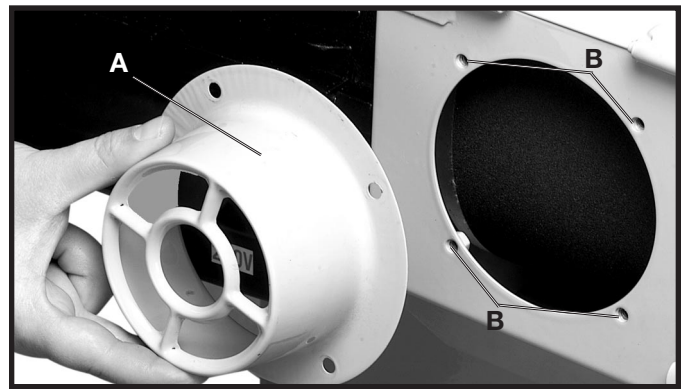

Fig. 17

3. **NOTE:** If this machine is to be used with a dust collection system, slide the 4" O.D. hose connector over the dust port as shown in Fig. 18.

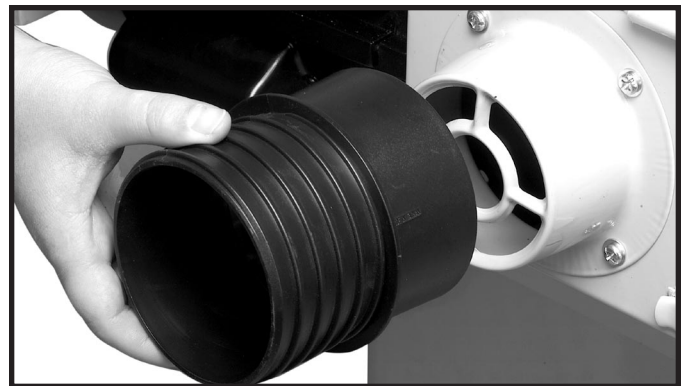

Fig. 18

## SANDING SPINDLE

1. Release latch lever (A) Fig. 19 on the belt guard.



Fig. 19

2. Move belt guard (B) down as shown in Fig. 20.

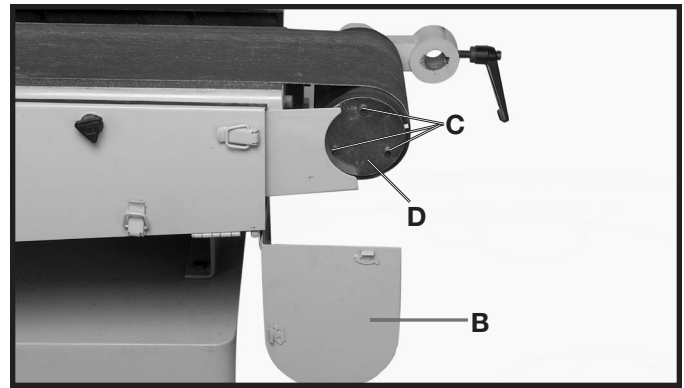

Fig. 20

3. Remove the three screws (C) and drum plate (D) Fig. 20.

4. Align the three holes in spindle (E) Fig. 21, with the three tapped holes (F) in the drum.

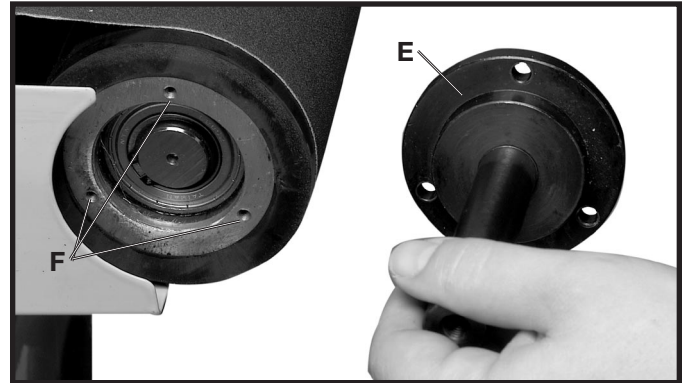

Fig. 21

5. Insert the three screws that were removed in **STEP 3**, through spindle and tighten securely.

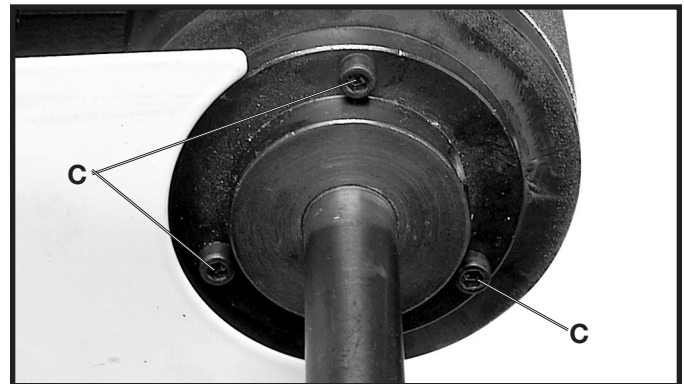

Fig. 22

6. Insert the rod (G) Fig. 23, on the sanding spindle table, through hole (H).

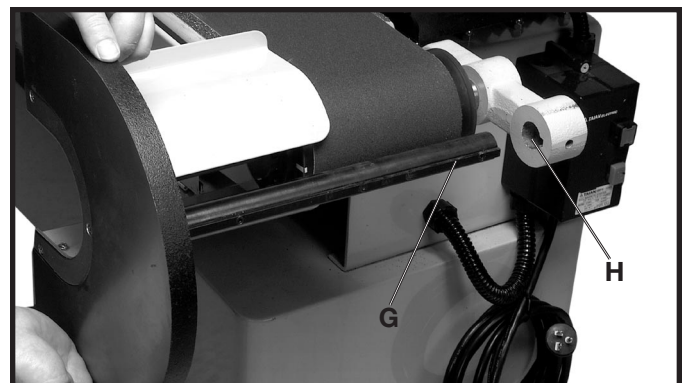

Fig. 23

7. Thread the ratchet handle (J) Fig. 24, into the tapped hole (K) and tighten securely.

**NOTE: ratchet handle (J) is spring loaded and can be repositioned by pulling out on the lever and repositioning it on the serrated nut located underneath the lever.**

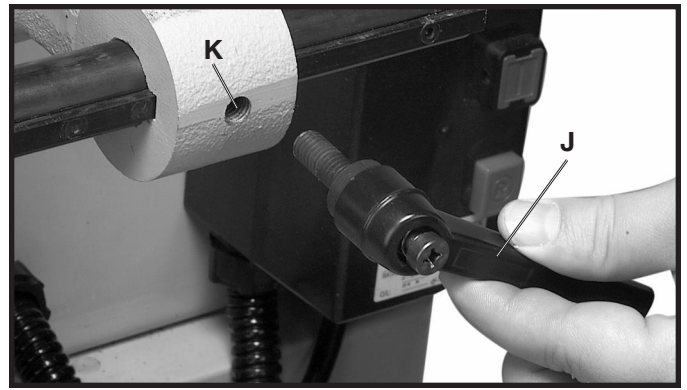

Fig. 24

8. Place one of the three rubber sanding drums and sand paper (L) Fig. 25 on the sanding spindle.

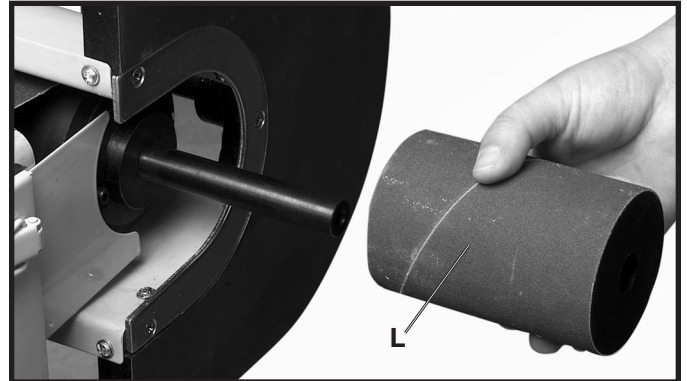

Fig. 25

9. Place the 5/16" spindle washer (M) Fig. 26, on a 5/16-18x1/2" hex head screw (N). Thread screw into tapped hole on end of sanding spindle. Place the rod (P) into the hole on the side of the spindle to lock the spindle. Tighten screw securely with the 12mm open end wrench.

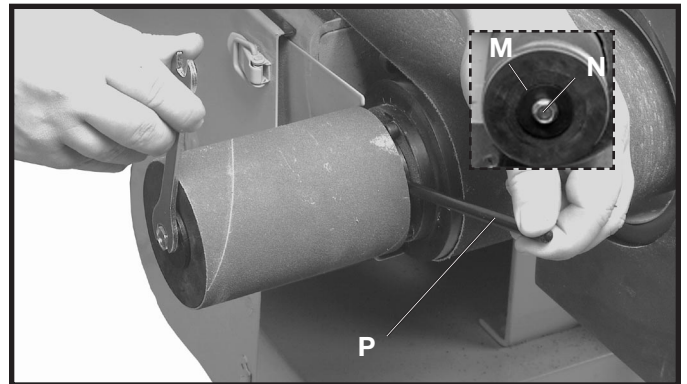

Fig. 26

10. Remove the three flat head screws (O) Fig. 27, that hold the table insert (P) to the sanding table.

11. Remove the 4" table insert (R) Fig. 27, and replace it with the appropriate table insert.

1-1/2" Drum	-	1-1/2" Table Insert
2" Drum	-	2" Table Insert
3" Drum	-	3" Table Insert

(See Fig. 5)

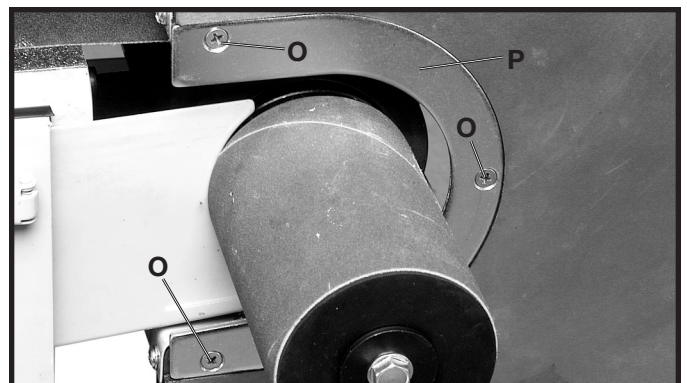

Fig. 27

12. Assemble appropriate table insert onto the table using the three screws that were removed in **STEP 10**.

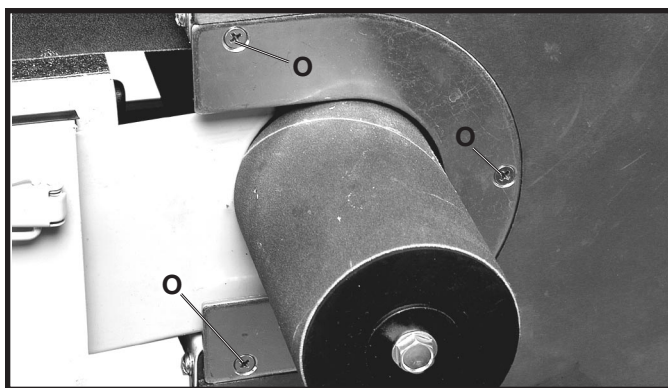

Fig. 28

## FENCE

If sanding with the belt in the horizontal position, the use of the fence is recommended.

1. Place the fence (A) on the table as shown in Fig. 29.
2. Align the slots (B) Fig. 29, in the fence with the tapped holes (C) in the table.

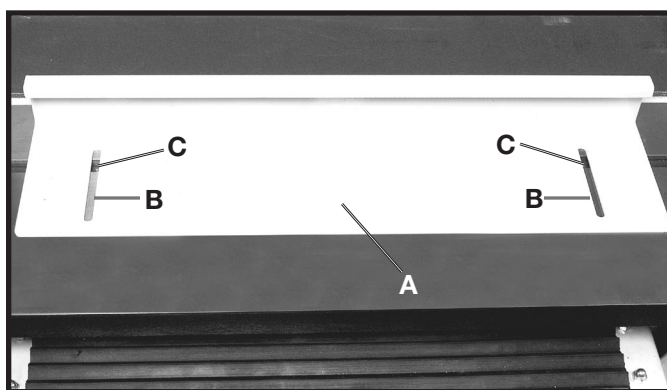

Fig. 29

3. Place a 5/16" flat washer (D) Fig. 30, on the fence knob (E).

4. Insert knob through slot (B) Fig. 30, and thread knob into tapped hole in table and tighten securely. Repeat this process for the remaining fence knob.

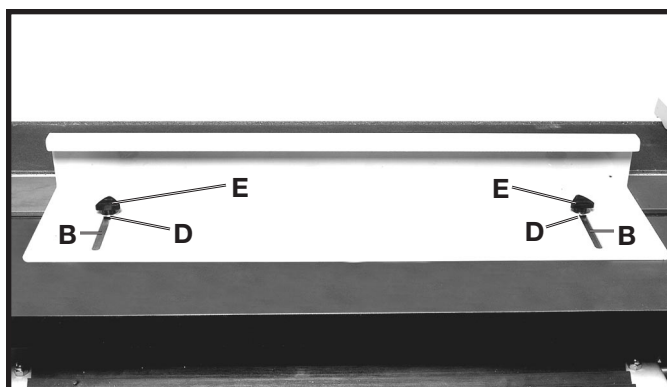

Fig. 30

# OPERATING CONTROLS AND ADJUSTMENTS

## STARTING AND STOPPING OSCILLATING EDGE SANDER

The power switch is located on the left side of the machine. To turn the machine “ON” press the green start button (A) Fig. 31. To stop the machine, push the red stop button (B).



Fig. 31

There is a stop button located at the top of the belt cover. To stop the machine, push the red stop button (C) Fig. 32.

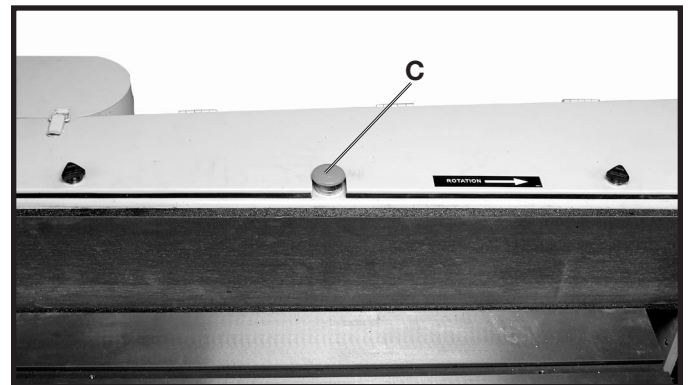

Fig. 32

## LOCKING SWITCH IN THE “OFF” POSITION

**IMPORTANT:** When the machine is not in use, the switch should be locked in the OFF position using a padlock (C) Fig. 33, with a 3/16" diameter shackle to prevent unauthorized use.



Fig. 33

## BELT TABLE HEIGHT

**⚠ WARNING** DISCONNECT MACHINE FROM POWER SOURCE.

1. Loosen ratchet handles (A) and (B) Fig. 34.



Fig. 34

2. Pull out on the table height wheel handle (C) Fig. 35.
3. Rotate table height wheel clockwise to raise the table and counter clockwise to lower the table.
4. When the table height is at the desired position tighten ratchet handles (A) and (B) Fig. 34.



Fig. 35

## TABLE DISTANCE TO BELT

**⚠ WARNING** DISCONNECT MACHINE FROM POWER SOURCE.

1. Move handles (C) and (D) Fig. 36 to the right as shown in Fig. 37.



Fig. 36

2. Grasp the front of the table (E) Fig. 38, and move the table in or out to the desired position.

**NOTE: THE DISTANCE FROM THE TABLE TO THE BELT SHOULD BE 1/16" OR LESS WHENEVER POSSIBLE.**

3. Move handles (C) and (D) Fig. 37 to the left as shown in Fig. 36 to lock the table in position.

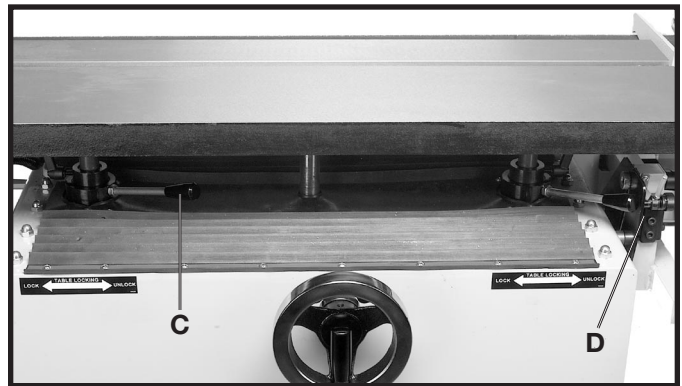

Fig. 37



Fig. 38



# ANGLE OF BELT SANDER

**⚠ WARNING** DISCONNECT MACHINE FROM POWER SOURCE.

1. The belt sander can be tilted from 0 degrees to the table up to 90 degrees to the table.
2. Move the table to the front of the machine. Grasp the tilting handle (C) Fig. 39.

**⚠ WARNING** GRASP THE TILTING HANDLE FIRMLY WHEN REPOSITIONING THE BELT SANDER.

3. Position the detent pin (A), as shown in Fig. 41.
4. Loosen ratchet handle (B) Fig. 40.
5. Push down on the handle (C) Fig. 39 until the pointer (D) Fig. 41 lines up with the desired angle on the scale (E).

6. Tighten ratchet handle (B) Fig. 41.

**NOTE: THE DETENT LOCK PIN (A) FIG. 40 ALLOWS FOR QUICK ADJUSTMENTS TO 0 DEGREES, 45 DEGREES, AND 90 DEGREES TO THE TABLE.**

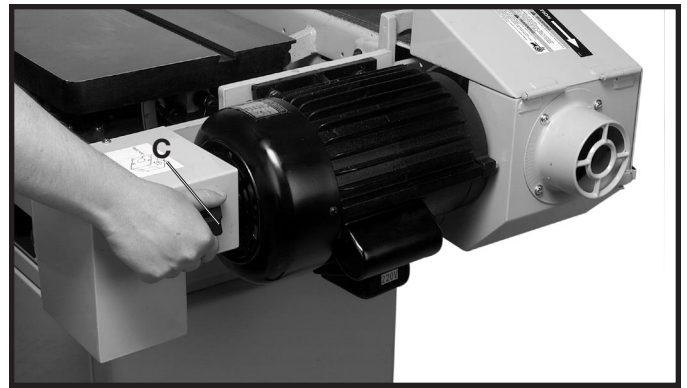

Fig. 39

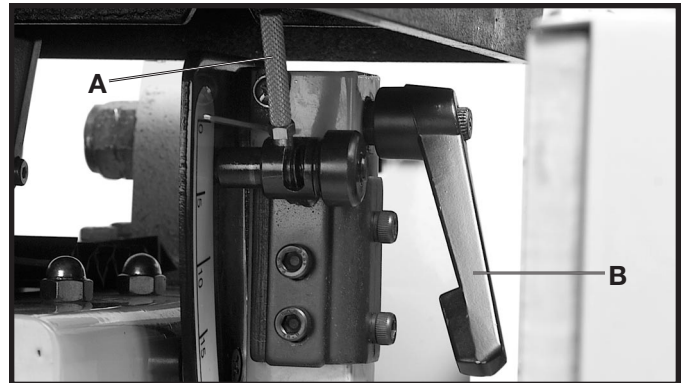

Fig. 40

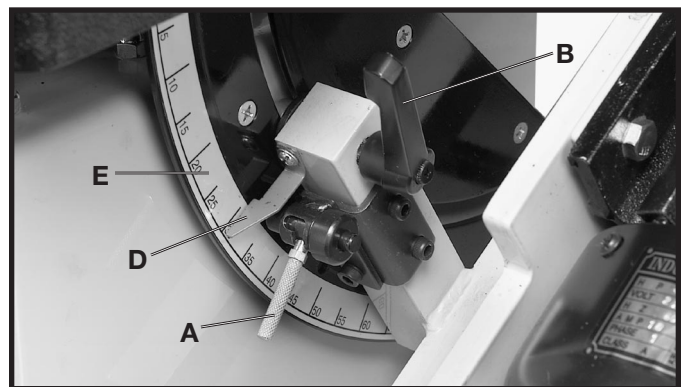

Fig. 41

# BELT TRACKING

**⚠ WARNING** DISCONNECT MACHINE FROM POWER SOURCE.

1. Loosen nut (A) Fig. 42.
2. Turn nut (B) Fig. 42, clockwise or counter clockwise to adjust belt tracking.
3. When belt is tracking properly, retighten nut (A) Fig. 42.



Fig. 42

# SPINDLE SANDER TABLE

**⚠ WARNING** DISCONNECT MACHINE FROM POWER SOURCE.

1. The table (A) Fig. 43, can be moved up or down.
2. Loosen ratchet handle (C) Fig. 43, move table (A) to desired position and tighten handle (C).

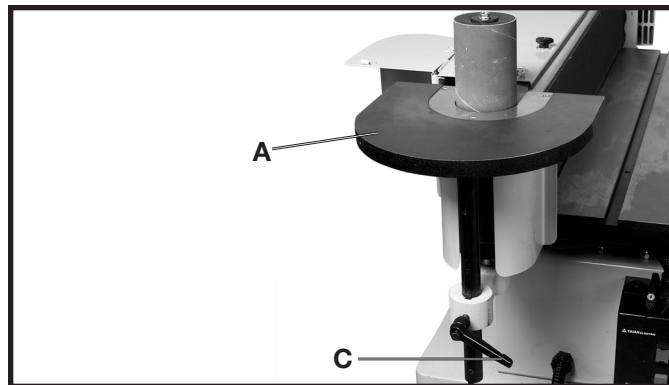

Fig. 43

3. The table can also be positioned on the oscillating belt by removing the table insert, and sliding the table down around the oscillating belt. Replace the table insert with the 4" table insert (D) Fig. 44, when using the sander table on the oscillating belt.

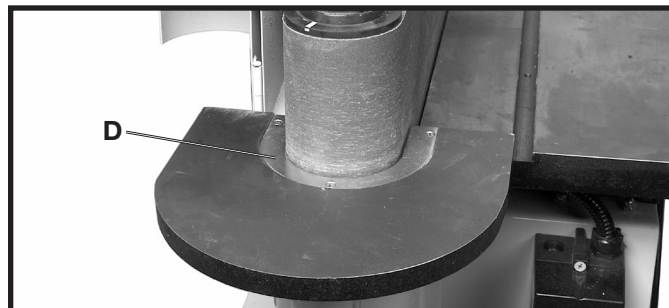

Fig. 44

# FENCE

**⚠ WARNING** DISCONNECT MACHINE FROM POWER SOURCE.

1. Loosen fence knobs (A) and (B) Fig. 45.
2. Move fence to desired position and tighten knobs (A) and (B) Fig. 45.

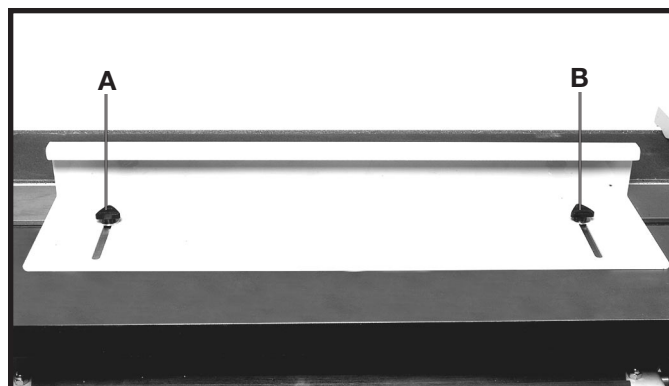

Fig. 45

# MITER GAGE

1. The miter gage is equipped with adjustable index stops at 90 degrees and 45 degrees right and left. Adjustment to the index stops can be made by loosening nuts (F) Fig. 46, and tightening or loosening the three adjusting screws (B).

2. To rotate the miter gage, loosen handle (A) Fig. 46, flip the stop link (D) down and out of the way, and move the body of the miter gage (C), to the desired angle.

3. The miter gage body (C) can stop at 90 degrees and 45 degrees both right and left by flipping the stop link (D) back up so that the stop link (D) will be able to contact the adjusting screws (B) at the desired 90 or 45 degree angle. To rotate the miter gage body past these points, the stop link (D) Fig. 46, must be down and out of the way.

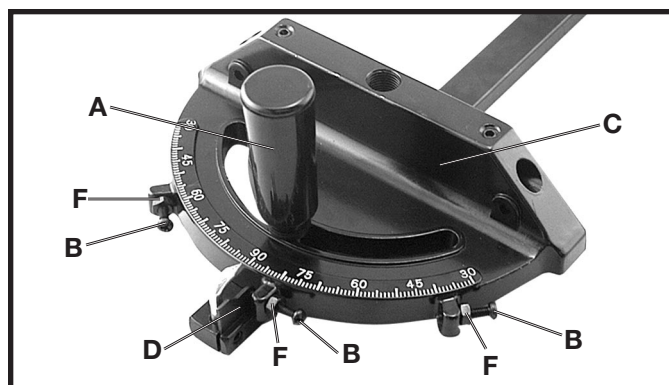

Fig. 46

4. Your miter gage is equipped with a plate (E) Fig. 47, which fits into the T-Slot groove in the table. This allows the miter gage to be pulled off the front edge of the table without falling.

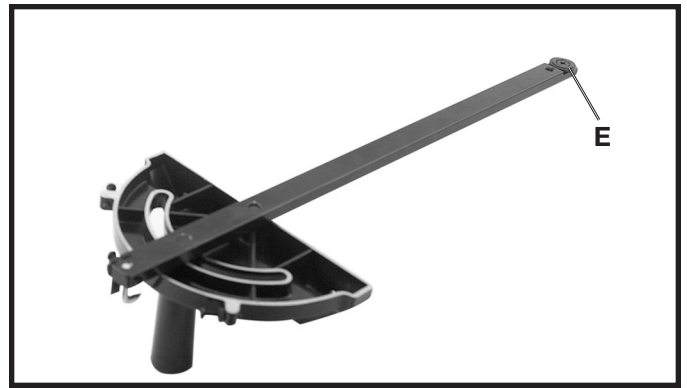

Fig. 47

## OPERATIONS

The Oscillating Edge Sander can be used to perform many different sanding operations. The following examples will show some of the applications that this machine can be used for.

1. Fig. 48 shows sanding with the fence.

**⚠ WARNING** Only use the fence when the belt sander is at 0 degrees to the table

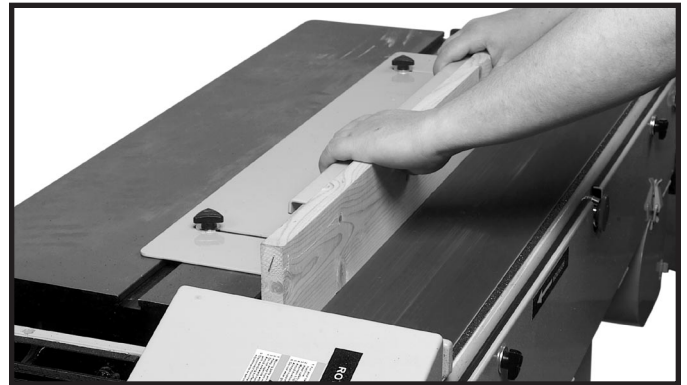

Fig. 48

2. Fig. 49 shows sanding with the miter gage.



Fig. 49

3. Fig. 50 shows sanding at 0 degrees to the table with out the fence.



Fig. 50

4. Fig. 51 shows sanding at 45 degrees to the table with the miter gage.

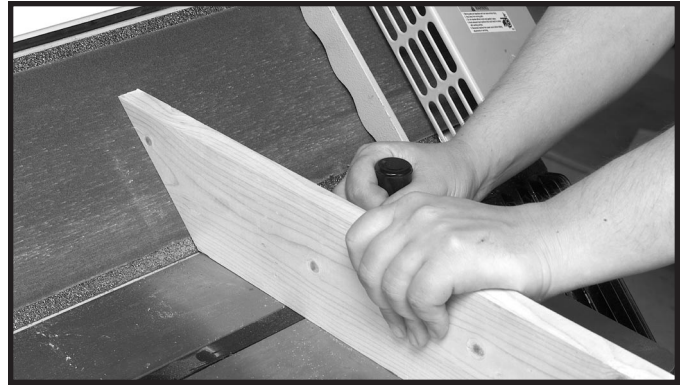

**Fig. 51**

4. Fig. 52 shows sanding at 90 degrees to the table with the miter gage.



**Fig. 52**

5. Fig. 53 shows the spindle sander being used in the vertical position. It is advisable to raise or lower the table periodically to prevent spot wear and improve drum life.



**Fig. 53**

## STORAGE

The Oscillating Spindle Sander has a convenient storage area for spindles, fence, miter gage, and any other components of the machine that are not in use.

Fig. 54 illustrates components of the Oscillating Edge sander stored in the base of the machine.



**Fig. 54**

# MAINTENANCE

## LUBRICATION

After the machine has been operated for approximately 500 hours, check oil level.

**⚠ WARNING** **DISCONNECT MACHINE FROM POWER SOURCE.**

1. Make sure that the belt sander is in the horizontal position as shown in Fig. 55.

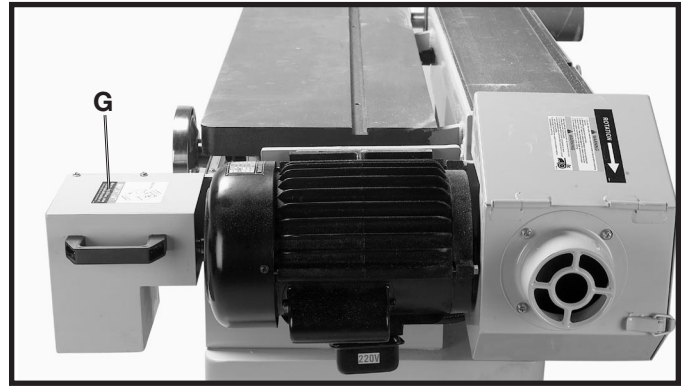

Fig. 55

2. Remove the two screws (A) Fig. 56, on top of the gear box cover (G) Fig. 55.

3. Remove the two screws, located right below screws (A) Fig. 56, on the bottom of the gear box cover. Remove the gear box cover.

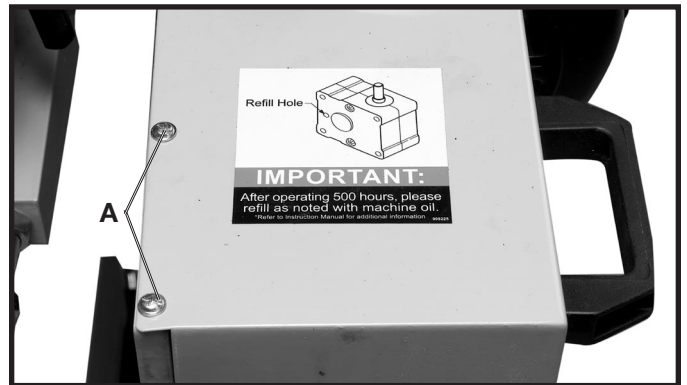

Fig. 56

4. Remove the screw (D) Fig. 57, on top of the gear box.

5. Fill the gear box with machine oil and replace screw (D) Fig. 57.

6. Replace the gear box cover and screws that were removed in **STEPS 2, 3, AND 4.**

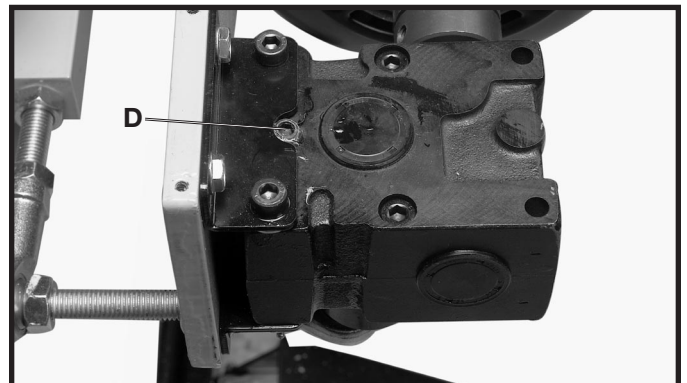

Fig. 57

# REMOVING THE DRUM

**⚠ WARNING** DISCONNECT MACHINE FROM POWER SOURCE.

1. Open the belt sander guards and remove the sanding belt.
2. Remove nut (A) and washer from the shaft (J) Fig. 59.

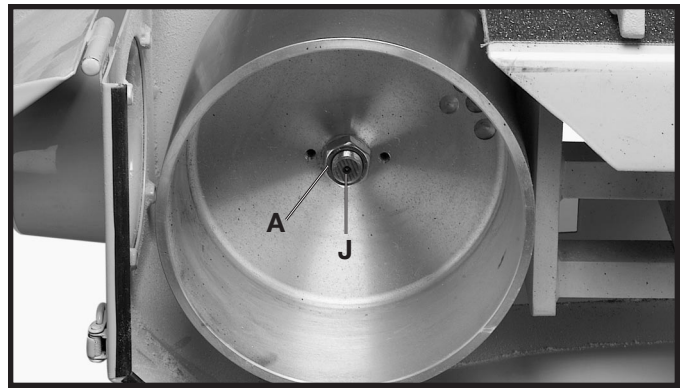

Fig. 59

3. Insert the two 1/4-20x1-3/4" socket head screws through holes (C) and (D) Fig. 60, on the retraction plate (E).
4. Thread screws (C) and (D) Fig. 60 into the two tapped holes (F) in the drum.

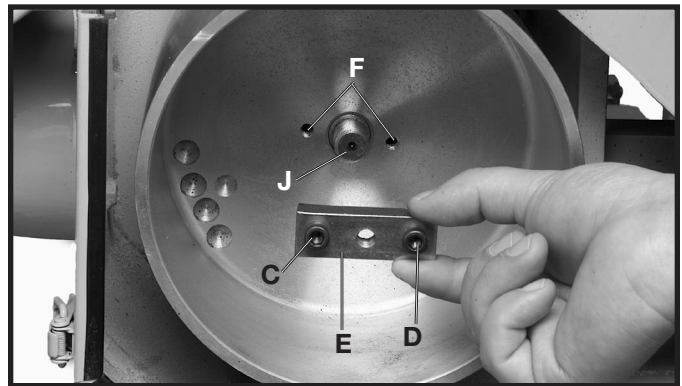

Fig. 60

5. Thread a 5/16-18 x 1-1/4" socket head screw (G) Fig. 61, into the tapped hole (H) in the retraction plate.
6. Turn screw (G) Fig. 61, against shaft (J) Fig. 60. This will pull the drum off the shaft.
7. To install drum, place the drum on the shaft, replace the washer and nut that were removed in **STEP 2** and tighten securely.

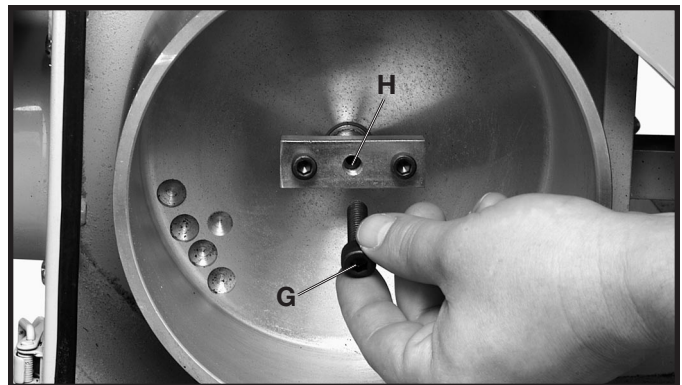

Fig. 61

# ACCESSORIES

A complete line of accessories is available from your Delta Supplier, Porter-Cable • Delta Factory Service Centers, and Delta Authorized Service Stations. Please visit our Web Site [www.deltamachinery.com](http://www.deltamachinery.com) for a catalog or for the name of your nearest supplier.

**▲ WARNING** Since accessories other than those offered by Delta have not been tested with this product, use of such accessories could be hazardous. For safest operation, only Delta recommended accessories should be used with this product.



## PARTS, SERVICE OR WARRANTY ASSISTANCE

All Delta Machines and accessories are manufactured to high quality standards and are serviced by a network of Porter-Cable • Delta Factory Service Centers and Delta Authorized Service Stations. To obtain additional information regarding your Delta quality product or to obtain parts, service, warranty assistance, or the location of the nearest service outlet, please call 1-800-223-7278 (In Canada call 1-800-463-3582).



### Two Year Limited Warranty

Delta will repair or replace, at its expense and at its option, any Delta machine, machine part, or machine accessory which in normal use has proven to be defective in workmanship or material, provided that the customer returns the product prepaid to a Delta factory service center or authorized service station with proof of purchase of the product within two years and provides Delta with reasonable opportunity to verify the alleged defect by inspection. Delta may require that electric motors be returned prepaid to a motor manufacturer's authorized station for inspection and repair or replacement. Delta will not be responsible for any asserted defect which has resulted from normal wear, misuse, abuse or repair or alteration made or specifically authorized by anyone other than an authorized Delta service facility or representative. Under no circumstances will Delta be liable for incidental or consequential damages resulting from defective products. This warranty is Delta's sole warranty and sets forth the customer's exclusive remedy, with respect to defective products; all other warranties, express or implied, whether of merchantability, fitness for purpose, or otherwise, are expressly disclaimed by Delta.

## PORTER-CABLE • DELTA SERVICE CENTERS (CENTROS DE SERVICIO DE PORTER-CABLE • DELTA)

Parts and Repair Service for Porter-Cable • Delta Machinery are Available at These Locations  
(Obtenga Refaccion de Partes o Servicio para su Herramienta en los Siguietes Centros de Porter-Cable • Delta)

### ARIZONA

Tempe 85282 (Phoenix)  
2400 West Southern Avenue  
Suite 105  
Phone: (602) 437-1200  
Fax: (602) 437-2200

### CALIFORNIA

Ontario 91761 (Los Angeles)  
3949A East Guasti Road  
Phone: (909) 390-5555  
Fax: (909) 390-5554

San Leandro 94577 (Oakland)  
3039 Teagarden Street  
Phone: (510) 357-9762  
Fax: (510) 357-7939

### COLORADO

Arvada 80003 (Denver)  
8175 Sheridan Blvd., Unit S  
Phone: (303) 487-1809  
Fax: (303) 487-1868

### FLORIDA

Davie 33314 (Miami)  
4343 South State Rd. 7 (441)  
Unit #107  
Phone: (954) 321-6635  
Fax: (954) 321-6638

Tampa 33609

4538 W. Kennedy Boulevard  
Phone: (813) 877-9585  
Fax: (813) 289-7948

### GEORGIA

Forest Park 30297 (Atlanta)  
5442 Frontage Road,  
Suite 112  
Phone: (404) 608-0006  
Fax: (404) 608-1123

### ILLINOIS

Addison 60101 (Chicago)  
400 South Rohlwing Rd.  
Phone: (630) 424-8805  
Fax: (630) 424-8895

Woodridge 60517 (Chicago)

2033 West 75th Street  
Phone: (630) 910-9200  
Fax: (630) 910-0360

### MARYLAND

Elkridge 21075 (Baltimore)  
7397-102 Washington Blvd.  
Phone: (410) 799-9394  
Fax: (410) 799-9398

### MASSACHUSETTS

Braintree 02185 (Boston)  
719 Granite Street  
Phone: (781) 848-9810  
Fax: (781) 848-6759

Franklin 02038 (Boston)  
Franklin Industrial Park  
101E Constitution Blvd.  
Phone: (508) 520-8802  
Fax: (508) 528-8089

### MICHIGAN

Madison Heights 48071 (Detroit)  
30475 Stephenson Highway  
Phone: (248) 597-5000  
Fax: (248) 597-5004

### MINNESOTA

Minneapolis 55429  
5522 Lakeland Avenue North  
Phone: (763) 561-9080  
Fax: (763) 561-0653

### MISSOURI

North Kansas City 64116  
1141 Swift Avenue  
Phone: (816) 221-2070  
Fax: (816) 221-2897

St. Louis 63119

7574 Watson Road  
Phone: (314) 968-8950  
Fax: (314) 968-2790

### NEW YORK

Flushing 11365-1595 (N.Y.C.)  
175-25 Horace Harding Expwy.  
Phone: (718) 225-2040  
Fax: (718) 423-9619

### NORTH CAROLINA

Charlotte 28270  
9129 Monroe Road, Suite 115  
Phone: (704) 841-1176  
Fax: (704) 708-4625

### OHIO

Columbus 43214  
4560 Indianola Avenue  
Phone: (614) 263-0929  
Fax: (614) 263-1238

Cleveland 44125  
8001 Sweet Valley Drive  
Unit #19  
Phone: (216) 447-9030  
Fax: (216) 447-3097

### OREGON

Portland 97230  
4916 NE 122 nd Ave.  
Phone: (503) 252-0107  
Fax: (503) 252-2123

### PENNSYLVANIA

Willow Grove 19090  
520 North York Road  
Phone: (215) 658-1430  
Fax: (215) 658-1433

### TEXAS

Carrollton 75006 (Dallas)  
1300 Interstate 35 N, Suite 112  
Phone: (972) 446-2996  
Fax: (972) 446-8157

Houston 77055

West 10 Business Center  
1008 Wirt Road, Suite 120  
Phone: (713) 682-0334  
Fax: (713) 682-4867

### WASHINGTON

Auburn 98001 (Seattle)  
3320 West Valley HWY, North  
Building D, Suite 111  
Phone: (253) 333-8353  
Fax: (253) 333-9613

Authorized Service Stations are located in many large cities. Telephone **800-438-2486** or **731-541-6042** for assistance locating one. Parts and accessories for Porter-Cable-Delta products should be obtained by contacting any Porter-Cable-Delta Distributor, Authorized Service Center, or Porter-Cable-Delta Factory Service Center. If you do not have access to any of these, call **800-223-7278** and you will be directed to the nearest Porter-Cable-Delta Factory Service Center. Las Estaciones de Servicio Autorizadas están ubicadas en muchas grandes ciudades. Llame al **800-438-2486** ó al **731-541-6042** para obtener asistencia a fin de localizar una. Las piezas y los accesorios para los productos Porter-Cable-Delta deben obtenerse poniéndose en contacto con cualquier distribuidor Porter-Cable-Delta, Centro de Servicio Autorizado o Centro de Servicio de Fábrica Porter-Cable-Delta. Si no tiene acceso a ninguna de estas opciones, llame al **800-223-7278** y le dirigirán al Centro de Servicio de Fábrica Porter-Cable-Delta más cercano.

## CANADIAN PORTER-CABLE • DELTA SERVICE CENTERS

### ALBERTA

Bay 6, 2520-23rd St. N.E.  
Calgary, Alberta  
T2E 8L2  
Phone: (403) 735-6166  
Fax: (403) 735-6144

### BRITISH COLUMBIA

8520 Baxter Place  
Burnaby, B.C.  
V5A 4T8  
Phone: (604) 420-0102  
Fax: (604) 420-3522

### MANITOBA

1699 Dublin Avenue  
Winnipeg, Manitoba  
R3H 0H2  
Phone: (204) 633-9259  
Fax: (204) 632-1976

### ONTARIO

505 Southgate Drive  
Guelph, Ontario  
N1H 6M7  
Phone: (519) 836-2840  
Fax: (519) 767-4131

### QUÉBEC

1515 ave.  
St-Jean Baptiste,  
Québec, Québec  
G2E 5E2  
Phone: (418) 877-7112  
Fax: (418) 877-7123

1447, Begin  
St-Laurent, (Montréal),  
Québec  
H4R 1V8  
Phone: (514) 336-8772  
Fax: (514) 336-3505

The following are trademarks of PORTER-CABLE-DELTA (Las siguientes son marcas registradas de PORTER-CABLE S.A.): Auto-Set®, BAMMER®, B.O.S.S.®, Builder's Saw®, Contractor's Saw®, Contractor's Saw II™, Delta®, DELTACRAFT®, DELTAGRAM™, Delta Series 2000™, DURATRONIC™, Emc2™, FLEX®, Flying Chips™, FRAME SAW®, Homecraft®, INNOVATION THAT WORKS®, Jet-Lock®, JETSTREAM®, 'kickstand®, LASERLOC®, MICRO-SET®, Micro-Set®, MIDI LATHE®, MORTEN™, NETWORK™, OMNIJIG®, POCKET CUTTER®, PORTA-BAND®, PORTA-PLANE®, PORTER-CABLE®&(design), PORTER-CABLE®PROFESSIONAL POWER TOOLS, Posi-Matic®, Q-3®&(design), QUICKSAND®&(design), QUICKSET™, QUICKSET II®, QUICKSET PLUS™, RIPTIDE™&(design), SAFE GUARD II®, SAFE-LOC®, Sanding Center®, SANDTRAP®&(design), SAW BOSS®, Sawbuck™, Sidekick®, SPEED-BLOC®, SPEEDMATIC®, SPEEDTRONIC®, STAIR EASE®, The American Woodshop®&(design), The Lumber Company®&(design), THE PROFESSIONAL EDGE®, THE PROFESSIONAL SELECT®, THIN-LINE™, TIGER®, TIGER CUB®, TIGER SAW®, TORQBUSTER®, TORQ-BUSTER®, TRU-MATCH™, TWIN-LITE®, UNIGUARD®, Unifence®, UNIFEEDER™, Unihead®, Uniplane™, Unirip®, Unisaw®, Univise®, Versa-Feeder®, VERSA-PLANE®, WHISPER SERIES®, WOODWORKER'S CHOICE™.

Trademarks noted with ™ and ® are registered in the United States Patent and Trademark Office and may also be registered in other countries. Las Marcas Registradas con el signo de ™ y ® son registradas por la Oficina de Registros y Patentes de los Estados Unidos y también pueden estar registradas en otros países.